

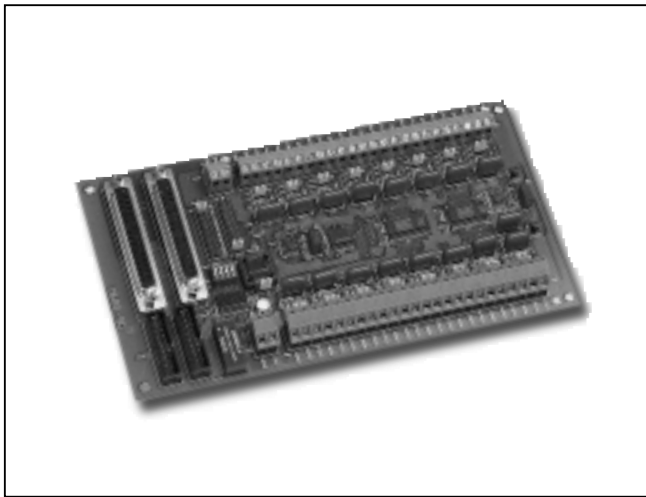

DB-889D

16 Channel Analog Multiplexer Board



Functional Description

The DB-889D is an expansion multiplexer/ amplifier board for use with A-82X and PCI-1800 series. Each 889D multiplexes 16 differential analog input channels into one analog input of the DAS board. It provides software programmable gains of 0.5, 1, 5, 10, 50, 100, 500 and 1000. Thermocouple measurement are handled easily with 889D. The board includes cold-junction sensing and compensation circuitry that provides a scaling of 24.4mV/°C. Biasing resistors are included for open thermocouple detection. The 889D can be cascaded to a total of 128 channels of voltage measurements or 112 channel of thermocouple measurement.

Features

- Connects directly to A-82X, PCI-1800 series DAS board
- Cold-junction compensation for thermocouples, thermocouple open detection
- Input filtering
- Software-programmable Instrumentation amplifier gain of 0.5, 1, 5, 10, 50, 100, 500 and 1000
- Daisy chain to ten DB-889D

Applications

- Energy management
- Signal conditioning
- Analog multiplexer

Specifications

- Accepts Thermocouple type: J, K, T, E, S, R, B
- Cold-Junction Compensation: +24.4 mV/°C (.1°C/bit), 0.0V at 0.0°C

Gain	Common Mode Rejection	Nonlinearity % of FSR	Settling Time
0.5	99dB	±0.0004	23us
1	99dB	±0.0004	23us
5	114dB	±0.0004	28us
10	114dB	±0.0004	28us
50	123dB	±0.0004	140us
100	123dB	±0.0004	140us
500	123dB	±0.0008	1300us
1000	123dB	±0.0008	1300us

Overvoltage Protection: +/- 30V Continuous
 Common mode voltage: ±10V max
 Analog output voltage: ±10V
 Power requirement: +5V@120mA
 Dimensions: 114 mm x 204 mm
 Operating temperature: 0 -50°C
 Storage temperature: -20°C, -70°C
 Humidity: 5% to 90 %

Order Description

- DB-889D: 16 Channel Multiplexer and Signal Conditioning Board With 37-PIN Cable & 20-Pin Flat Cable

Block Diagram

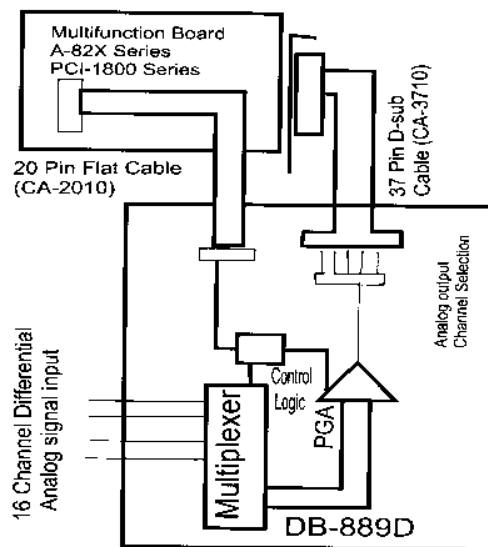

Daughter Board