

# STEP-200

## 2-AXIS, High-speed stepper Motor Controller

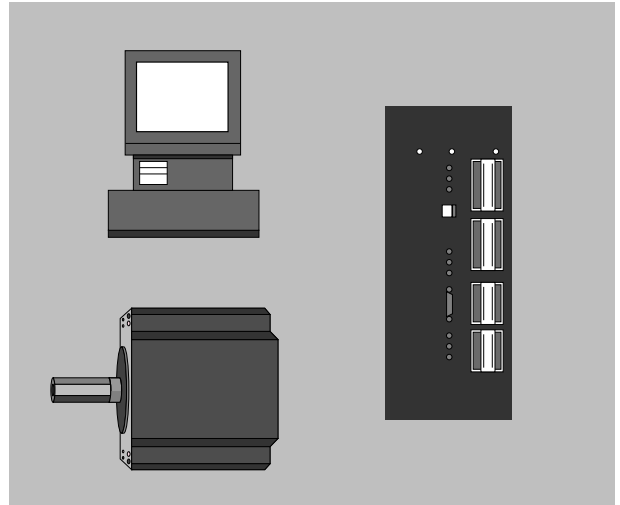
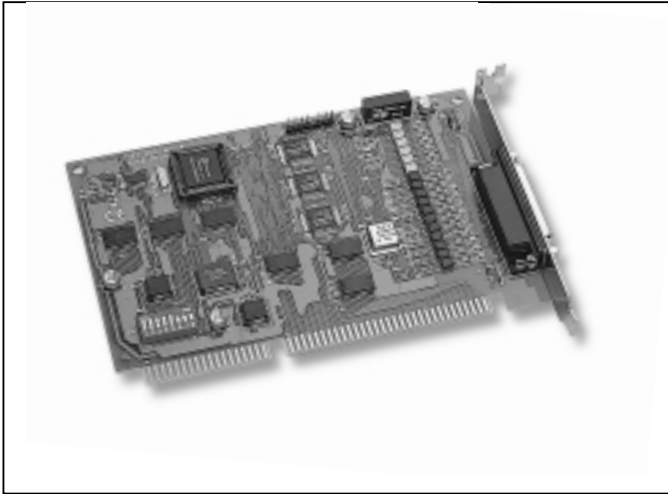

### Function Description

STEP-200 is a 2-axis, command-type, stepper motor controller board. It also can be used to control pulse-type servomotor. The embedded CPU of STEP-200 performs the motion commands transferred from PC to increase the system performance. A 2K byte FIFO is used as a command buffer. This buffer provides 1,360ms time buffer. Therefore, STEP-200 board is suitable for windows operation system. The STEP-200 board provides DOS, Windows 95, Windows NT, LabView drivers. The user may use our encoder-300 encoder interface board to work with STEP-200 to implement a closed-loop stepper-motor control system.

### Features

- 2-axis independent, simultaneous stepper motor control/servo motor control (pulse input type)
- DOS, windows 95, windows NT, LabView driver support
- Embedded CPU
- Command type interface
- Linear, circular interpolation
- Output pulse modes: CW/CCW or pulse/direction
- 2500Vrms optical isolated signal output

- Output polarity can be programmable
- OEM version call

### Applications

- X-Y table control
- Robotics
- Mechanical positioning control

### Specifications

- Stepper channels: 2
- Step rate: 1pps~250Kpps
- Max. step count: +/- (2<sup>32</sup>-1) steps
- Acceleration/deceleration: automatic trapezoidal acceleration/deceleration
- Limit switch inputs: 5 optical isolated digital inputs per axis (home, forward/reverse end limit, forward/reverse high speed limit)
- Output driving capability: 15mA source current at 5V; 50mA sink current at 0.4V
- Output pulse signal: two pulse (CW/CCW) mode or onepulse (pulse, direction) mode. Optically couple with 330Ω pull-up resistor
- Output polarity: Positive/Negative, Programmable

- Connector: D-sub 25 connector for limit switch and pulse output
- Power Requirements: +5V: 500mA typ.
- Environmental: Operating temp range: 0° to 60°C Storage temp range: -20°C to 70°C Humidity: 95% non-condensing Weight: 112g Dimensions: 167mm x 108mm

### DDA Technology

The DDA chip is the heart of STEP-200 board, it will generate equal-space pulse train corresponding to specific pulse number during a DDA period. This mechanism is very useful to execute pulse generation and interpolation function. The DDA period can be determined by DDA cycle. When DDA cycle set to 1, the DDA period is equal to 8.192ms. The output pulse number can be set to 0-2047, therefore the maximum output pulse rate will be 249.877kpps. The minimum output pulse rate is 0.96pps when set DDA cycle=254 (DDA period =1040.38ms) and pulse number=1)



# STEP-200

## 2-AXIS, High-speed stepper Motor Controller

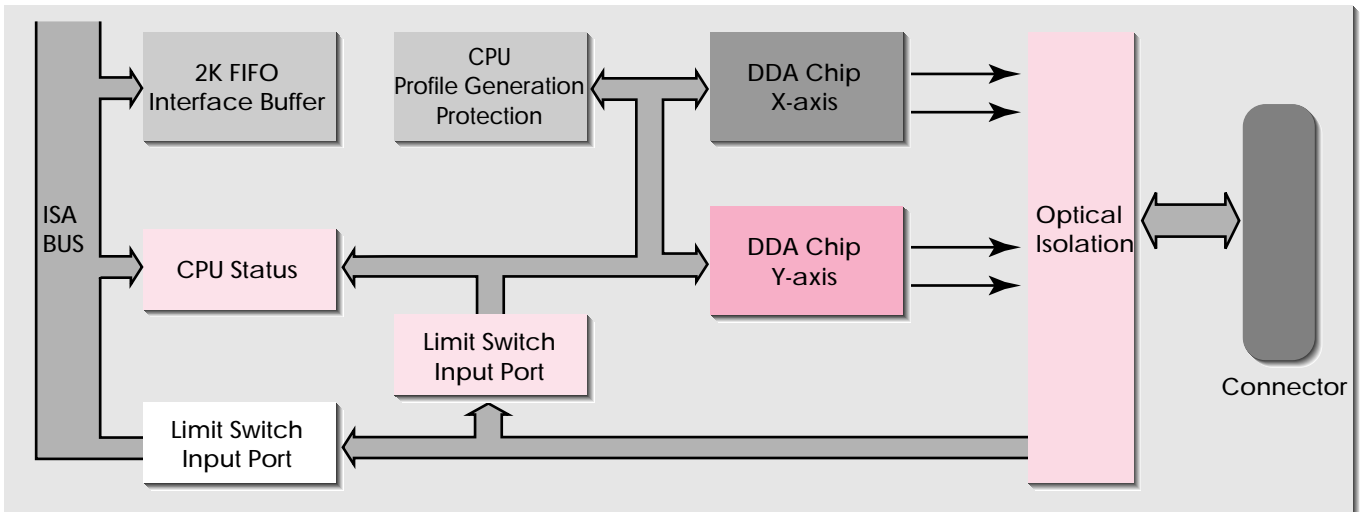

Figure A: Block Diagram

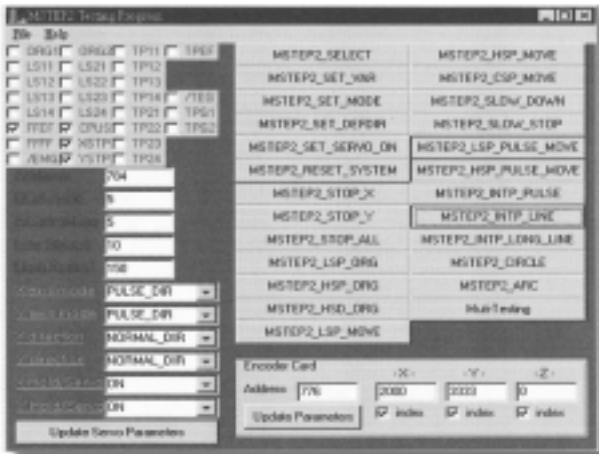

Figure B: Control Panel

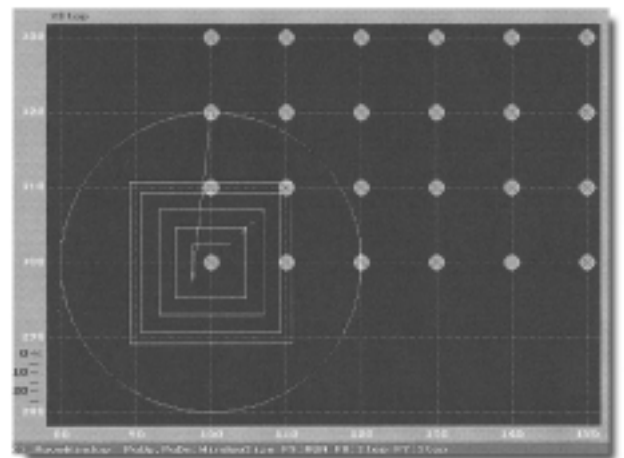

Figure D: Customer made Machine-Control Software

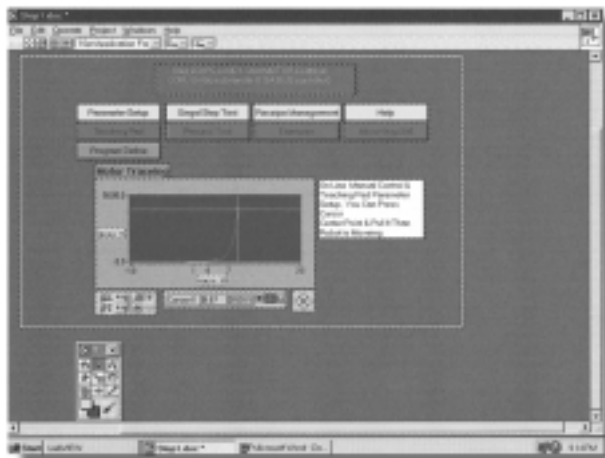

Figure C: LabView environment

### Software

- Step-200 Development Toolkit for DOS
- Step-200 Development Toolkit for Win95
- Step-200 Development Toolkit for WinNT

### Order Description

- Step-200  
2-axis stepper motor controller board

### Options

- Step-200 LabVIEW Development Toolkit for Win95
- Step-200 LabVIEW Development Toolkit for WinNT
- DN-25: Terminal Board with one 9-pin D-Sub cable and one 25-pin D-Sub cable